

直流电抗器(DCR) DC Reactor

■ 产品概述(Product Introduction)

直流平波电抗器用于整流回路之中，抑制整流后的波纹，改善输出波形，保证设备的正常运行。

DC smoothing reactor are used in rectifier circuit to suppress ripple after rectification, improve the output waveform, and ensure the normal operation of the DC devices.

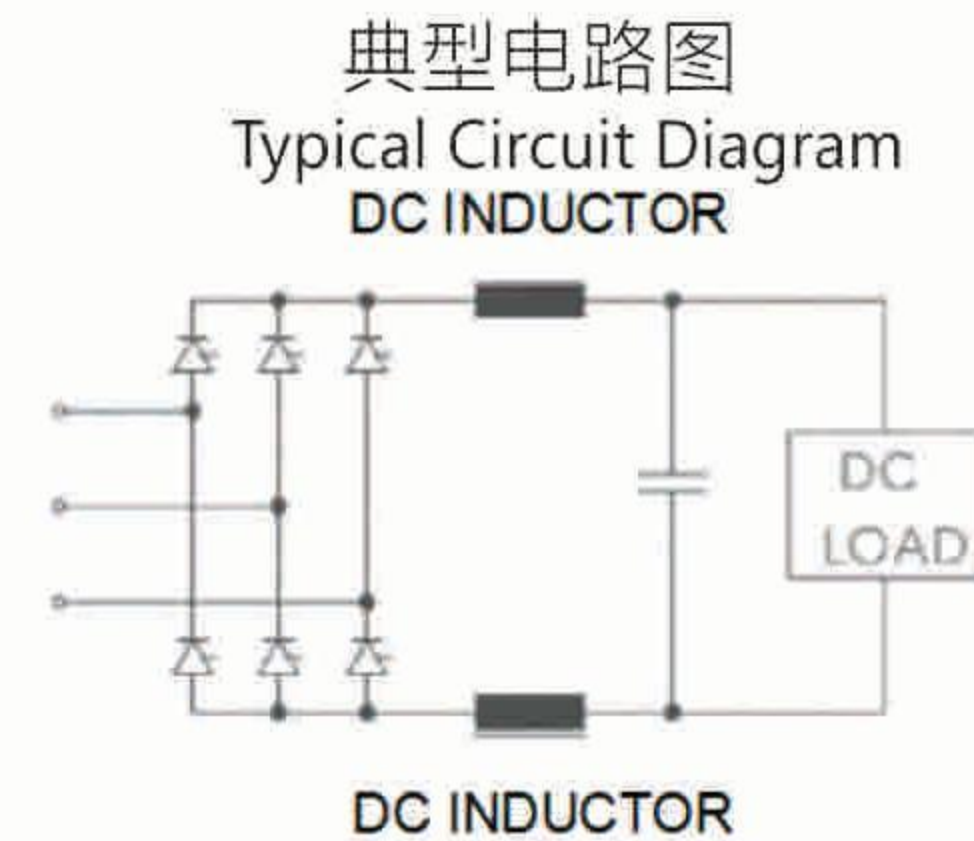
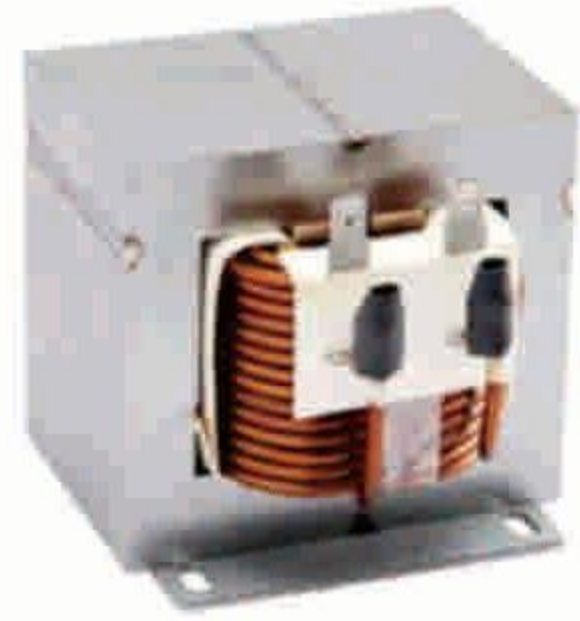

■ 产品应用(Product Application)

- 1.改善电容滤波造成的输入电流波形畸变
- 2.减少和防止因冲击电流造成整流桥损坏和电容过热
- 3.提高功率因数
4. 限制电网电压的瞬变
- 5.与并联连接的电容一起降低直流中的纹波，以排除对负载的不利影响

- 1.Suppress the input current waveform distortion caused by capacitive filtering
- 2.Reduce and avoid the damage to rectifier bridge and overheat of capacitor both of which arise form surge current
- 3.Improve the power factor
- 4.Limit the grid voltage mutation
- 5.Together with a capacitor connected in parallel, the ripple in the DC is reduced to exclude negative effects on the load

■ 技术规格(Technical Specification)

- 1.额定电压:220 ~ 1140VAC
- 2.额定频率: 50/60Hz
- 3.额定电流: 3 ~ 1600A
- 4.绝缘等级: F、H
- 5.使用环境: -10 ~ +45℃，额定值不会降低。最高可达+55℃，在45℃以上，每升高1℃，额定电流降低2%
- 6.防护等级: IP00-IP22
- 7.过载能力: 1.5 × 额定电流，持续60s
- 8.噪音: ≤65dB
- 9.温升: ≤ 85K
- 10.抗电强度: 铁芯-绕组 绕组-绕组3000VAC/50Hz/60s 无飞弧击穿
- 11.绝缘电阻: 1000VDC, ≥100MΩ
- 12.海拔高度不超过2000米
- 13.运行环境温度-25 ~ +45℃,相对湿度不超过90%
- 14.周围无有害气体，无易燃易爆物品
- 15.周围环境应有良好的通风条件，如装在柜内，应加装通风设备

- 1.Rated Voltage: 220 ~ 1140VAC
- 2.Rated Frequency: 50/60Hz
- 3.Rated Current: 3 ~ 1600A
- 4.Insulation Class: F, H
- 5.Operation Environment: -10 ~ +45℃, the rated value doesn't decrease.decrease. The tolerance temperature is up to +55℃. Above +45℃, the rated current decreases by 2% for every 1℃ increase
- 6.Protection Class: IP00-IP22
- 7.Overload Capacity: 1.5 x rated current, 60s
- 8.Noise: ≤65dB
- 9.Temperature Rise: ≤85K

10. Dielectric Strength: core-winding, winding-winding 3000VAC/50Hz/60s, no electric arc or electric breakdown
11. Insulation Resistance: 1000VDC, $\geq 100M\Omega$
12. Work under 2000m
13. Ambient Temperature $-25 \sim +45^{\circ}C$, and the relative humidity is not over 90%
14. No hazardous gas, flammable and explosive
15. With well-ventilated condition. Ventilation devices shall be mounted if reactors are installed in cabinets

■ 执行标准(Applicable Standard)

IEC 60076-6 Reactors
 GB/T1094.6 Reactors
 JB9644 Reactors or semiconductor electric drive

■ 产品尺寸图(Product Size)

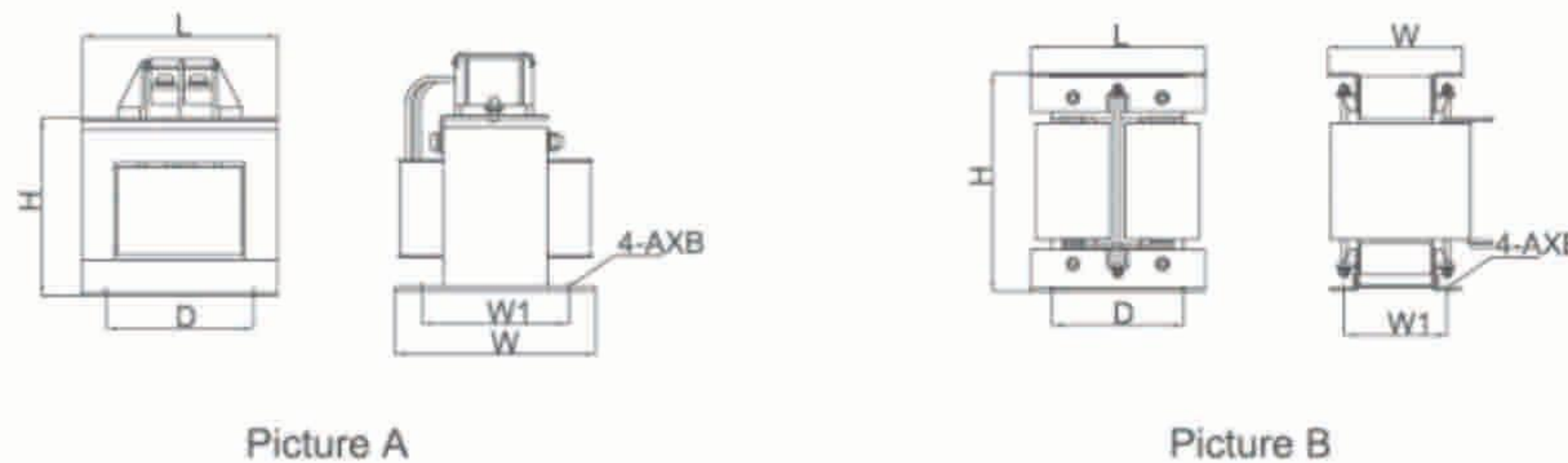

型号 Type	图号 Picture No.	适配功率 Power (kW)	额定电流 Rated Current(A)	电感量 Inductance (mH)	绝缘等级 Insulation Class	尺寸 Dimension(±5mm)					
						L	D	W	W1	H	A*B
DCR-0010-6M30-0.4DC	A	4	10	6.3	F ₂ H	100	80	100	70	125	6*11
DCR-0015-3M60-0.4DC		5.5	15	3.6	F ₂ H	110	87	120	70	135	6*11
DCR-0020-3M60-0.4DC		7.5	12	3.6	F ₂ H	110	87	120	70	135	6*11
DCR-0030-2M00-0.4DC		11	30	2	F ₂ H	110	87	120	70	135	6*11
DCR-0040-2M00-0.4DC		15	40	2	F ₂ H	110	87	120	70	135	6*11
DCR-0040-1M30-0.4DC		18.5	40	1.3	F ₂ H	110	87	120	70	135	6*11
DCR-0050-1M08-0.4DC		22	50	1.08	F ₂ H	120	95	135	85	145	8.4*13
DCR-0065-0M80-0.4DC		30	65	0.8	F ₂ H	138	111	150	85	170	8.4*13
DCR-0080-0M70-0.4DC		37	80	0.7	F ₂ H	138	111	150	85	170	8.4*13
DCR-0100-0M54-0.4DA		45	100	0.54	F ₂ H	138	111	150	85	170	8.4*13
DCR-0120-0M45-0.4DA	55	120	0.45	F ₂ H	155	125	160	90	195	9*18	
DCR-0160-0M36-0.4DA	B	75	160	0.36	F ₂ H	165	100	130	98	215	9*18
DCR-0200-0M33-0.4DA		90	200	0.33	F ₂ H	165	100	130	98	215	11*18
DCR-0250-0M26-.04DA		110	250	0.26	F ₂ H	210	176	150	115	255	11*18
DCR-0300-0M26-0.4DA		132	300	0.26	F ₂ H	210	176	150	115	255	11*18
DCR-0350-0M17-0.4DA		160	350	0.17	F ₂ H	210	176	150	115	255	11*18
DCR-0450-090U-0.4DA		185	450	0.09	F ₂ H	220	191	150	115	280	11*18
DCR-0500-060U-0.4DA		220	500	0.06	F ₂ H	220	191	150	115	280	11*18
DCR-0650-050U-0.4DA		300	650	0.05	F ₂ H	230	208	160	125	280	11*18
DCR-0800-050U-0.4DA		380/400	800	0.05	F ₂ H	250	200	245	144	320	11*18
DCR-1000-050U-0.4DA		450	1000	0.05	F ₂ H	250	200	280	146	360	11*18
DCR-1200-050U-0.4DA	500	1200	0.04	F ₂ H	250	200	280	164	390	11*18	

备注：其他规格尺寸，可根据用户要求制造。 Remark: Customized if necessary.

■ 成品识别码 (Product Identification Code)

DCR	0060	0M24	0.4SC
直流电抗器 DC Reactor	额定电流 Rated Current	电感量 Inductance Value M: mH H: μH	0.4: Rated Voltage 0.2=220V,0.4=380V,0.7=690V,1.1 = 1140V D: Single Phase S: Three Phase C: Copper A: Aluminum

对应CE认证的型号Corresponding CE code:

DCR	400SC	0006F/H
直流电抗器 DC Reactor	400: 额定电压 Rated Voltage, 1~3300V S: Three Phase C: Copper L: Aluminum	0005: 额定电流 Rated Current, 0.1~5000A